

dMS Explosion-proof multi-tone alarm sounder

- Loud, explosion-proof electronic multi-tone alarm sounder
- Certified for gas and dust hazardous areas of zone 1, 2, 21, 22
- Flame-proof enclosure "d"
- Terminal connection chamber "increased safety e"
- 32 signal tones, 2 tones can be switched externally
- Housing made of copper-free seawater-resistant aluminium, black plastic sound protection hood
- Degree of protection IP 66
- Maximum sound pressure 115 dB (A) in 1 m
- Volume can be reduced in 3 steps of 10 dB each
- Protection class I, wide voltage range

II 2 G Ex d e IIB + H2 T6 Gb

II 2 D Ex tb IIIC T85° Db

-50 °C ≤ Ta ≤ +60 °C

Zone 1, 2, 21, 22



TECHNICAL DATA

Housing	copper-free, seawater-resistant aluminium yellow/blue, sound protection hood Polyamide black
Type of mounting	Bracket for wall mounting, Sound outlet opening at bottom
Cable entry	M20 × 1.5 (5.5–13 mm)
Connection technology	bis 2,5 mm ²
Power consumption	max. 14 W
Tone	32 Tones, 2 Tones can be switched externally, see tone table
Volume	115 dB (can be adjusted with DIP switch)
Duty cycle	100 %
Operating temperature	-50 °C / +60 °C
Degree of protection	IP66
Approval	PTB 14 ATEX 1005
Insulation class	I
Weight	2,8 kg

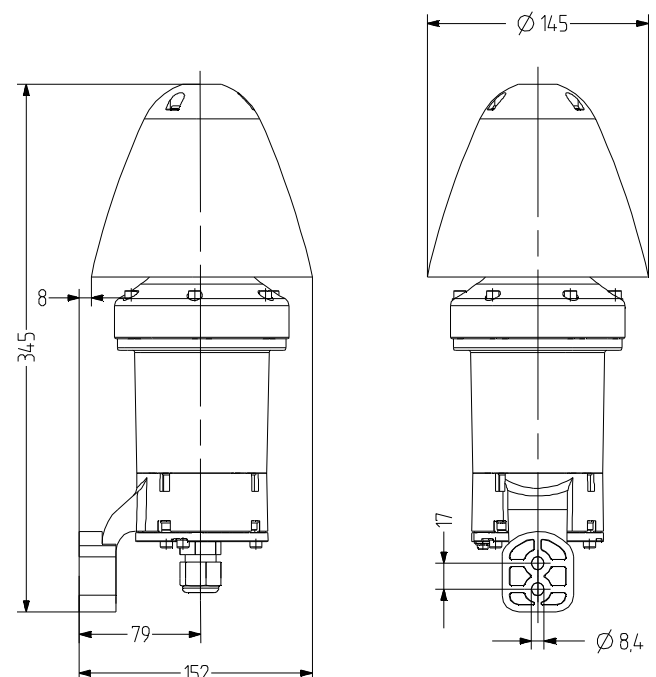

dMS

ORDER DATA

Type	Nominal voltage	Voltage range (V)	Nominal current (A)	Order number
dMS1	85-265 V AC	+/- 10 %	0,093	371 000 313
dMS2	24 V DC	+/- 10 %	0,460	371 000 005



MPL

ACCESSORIES

Type	Type of accessory	Order number
MPL	Mounting plate including explosion-proof junction box	335 500 000