

# DATASHEET - CP 150 Ex MANUAL CALL POINT

## AUDIBLE & VISUAL SIGNALLING EQUIPMENT



### DESCRIPTION - CP 150 Ex MANUAL CALL POINT "BREAK GLASS"

This manual call point «break glass» is certified for use in Atex/explosive atmosphere, zone 1 & 2 for gas and zone 21 & 22 for dust. It is dedicated for Oil & Gas, chemical, petrochemical, pharmacy industries, marine and Offshore applications. It's designed for corrosive environments and hazardous area.

The apparatus is compatible with PLC, ESD, DCS systems via output 4-20mA. The test function is built in, visualisation functions, line detection, glass protection and hammer are optional.

Housing is moulded in Glass-Reinforced Polyester (GRP), dyed in the mass and protected by an UV resistant paint.

A complete range of accessories is available to customize a products. (see accessories annex)



- zone 1 & 2
- zone 21 & 22

### PRODUCT CODE CONFIGURATOR

SWITCH	DUTY LABEL	TAG LABEL	LED INDICATOR	FEATURES	CABLE ENTRY	FINISH COLOUR
SINGLE = 1 X C/O	Y = YES	Y = YES	<span style="color: red;">■</span> <span style="color: green;">■</span> L = RED & GREEN	F = LIFT FLAP	A = M20	<span style="color: red;">■</span> RD = RED
			<span style="color: red;">■</span> R = RED	R = RESISTOR	B = M25	<span style="color: yellow;">■</span> YW = YELLOW
DOUBLE = 2 X C/O	N = NO	N = NO	<span style="color: green;">■</span> G = GREEN	D = DIODE	C = 1/2" NPT	<span style="color: blue;">■</span> BU = BLUE
			N = NO LED	N = NO FEATURES	D = 3/4" NPT	<span style="color: black;">■</span> BL = BLACK  <input type="checkbox"/> OR = OTHER ON REQUEST

ADD THE CODES RELATED TO THE FEATURES REQUIRED TO CP 150:

--	--	--	--	--	--	--

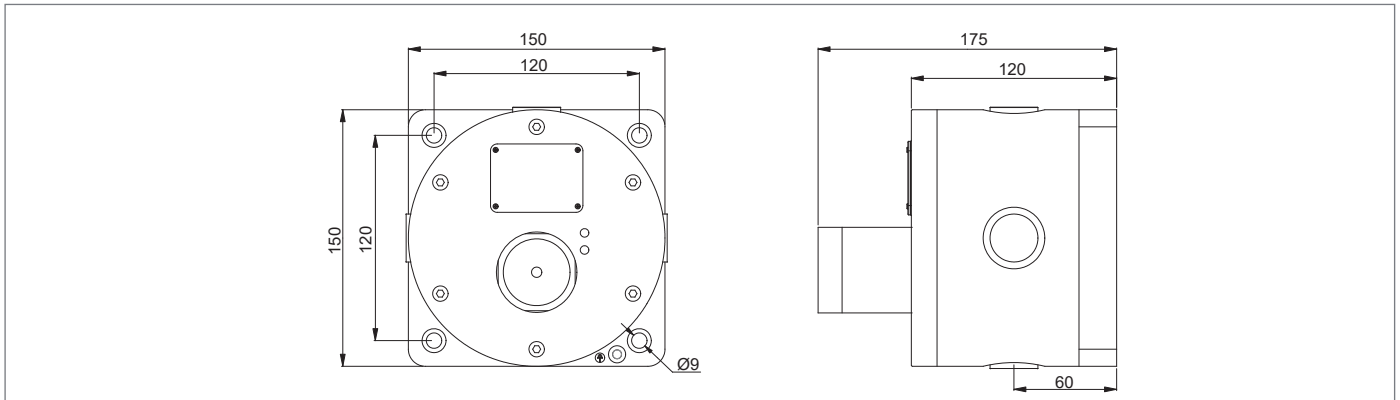

# DATASHEET - CP 150 Ex MANUAL CALL POINT

## AUDIBLE & VISUAL SIGNALLING EQUIPMENT

### TECHNICAL DATA

<b>MATERIAL</b>	<ul style="list-style-type: none"> <li>• <b>ENCLOSURE:</b> Glass-Reinforced Polyester (GRP)</li> </ul>
<b>COLOUR</b>	<ul style="list-style-type: none"> <li>• <b>RED</b> : RAL 3001 - <b>YELLOW**</b> : RAL1018 - <b>BLUE**</b> : RAL5005 - <b>BLACK**</b> : RAL9005</li> </ul>
<b>INGRESS PROTECTION</b>	<ul style="list-style-type: none"> <li>• IP66/67</li> </ul>
<b>AMBIENT TEMPERATURE FOR OPERATION</b>	<ul style="list-style-type: none"> <li>• <b>T6</b> = - 40°C ~ + 55°C , <b>T5</b> = - 40°C ~ + 60°C, <b>T4</b> = - 40°C ~ + 70°C</li> </ul>
<b>CERTIFICATION</b>	<ul style="list-style-type: none"> <li>• <b>Nemko</b> 13 ATEX 1564X, IECEX NEM 13.0034X</li> </ul>
<b>EX CODE</b>	<ul style="list-style-type: none"> <li>•  II 2 GD Ex d IIC T6 Gb, Ex tb IIIC T85°C</li> </ul>
<b>STANDARD</b>	<ul style="list-style-type: none"> <li>• EN / IEC 60079-0, EN / IEC 60079-1, EN / IEC 60079-31</li> </ul>
<b>ATEX AREA ZONE</b>	<ul style="list-style-type: none"> <li>• <b>Gas zone:</b> 1 &amp; 2 <b>Dust zone:</b> 21 &amp; 22</li> </ul>
<b>AMBIENT HUMIDITY*</b>	<ul style="list-style-type: none"> <li>• until 95% with ice*</li> </ul>
<b>RATED IMPULSE WITHSTAND VOLTAGE</b>	<ul style="list-style-type: none"> <li>• 1 kV according to IEC 61000-4-5</li> </ul>
<b>CONTACT TYPE</b>	<ul style="list-style-type: none"> <li>• 1x C/O or 2x C/O (1)</li> </ul>
<b>CONVENTIONAL THERMAL COURANT (Ith)</b>	<ul style="list-style-type: none"> <li>• AC 125/250 V (50/60Hz) =11A*** ; 30V DC = 6A***; 125 V DC = 0,3A***; 250 V DC = 0,6A***</li> </ul>
<b>MINIMUM VOLTAGE AND COURANT</b>	<ul style="list-style-type: none"> <li>• DC 5V 10mA</li> </ul>
<b>SHORTS CIRCUIT PROTECTION</b>	<ul style="list-style-type: none"> <li>• 10 A gG</li> </ul>
<b>CABLES ENTRY</b>	<ul style="list-style-type: none"> <li>• 4 x M20, M25**, 1/2" NPT**, 3/4" NPT** or other** (Specify)</li> </ul>
<b>TERMINAL</b>	<ul style="list-style-type: none"> <li>• From 22 to 14 AWG - from 0.50 mm<sup>2</sup> to 2.5 mm<sup>2</sup></li> </ul>
<b>NET WEIGHT</b>	<ul style="list-style-type: none"> <li>• 4.2 Kg</li> </ul>
<b>LINE RESISTOR**</b>	<ul style="list-style-type: none"> <li>• 470 Ohms**</li> </ul>
<b>SIGNALLING LED**</b>	<ul style="list-style-type: none"> <li>• <b>Green</b> U =24VDC I= 10 mA ; <b>Red</b> U=24V DC I = 20mA</li> </ul>

\* = without runoff - \*\* = optional - \*\*\* = resistive load - cable gland and blind plug not provided