

HP-10(T)

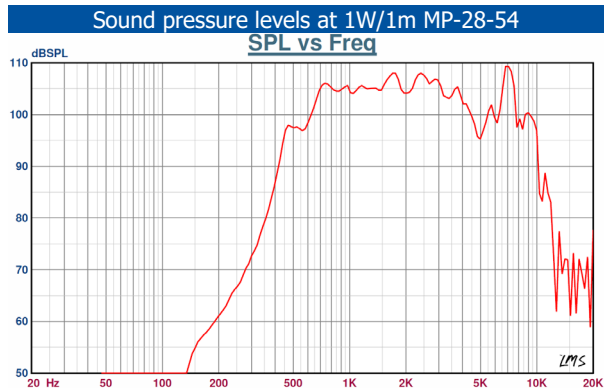
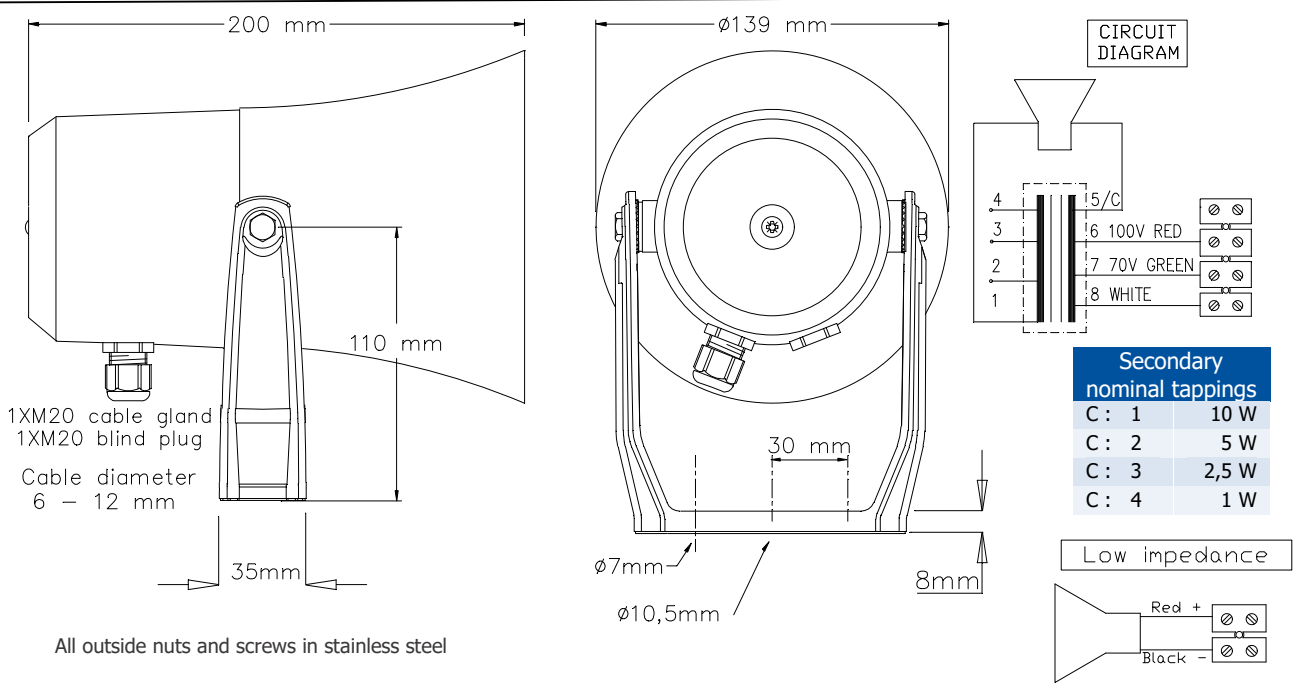

Specifications	
Material / Color	Ronfalin C110 (PC+ABS) / RAL 7035
Mounting	Bracket
Termination	Screw terminal
Weight w/transformer	1,1 kg
IP-rating	66/67
Max. / min. amb. temp	90°C / -50°C
Rated power	10 W
SPL 1W/1m	107 dB
SPL rated power	117 dB
Effective freq. range	370 – 12000 Hz
Dispersion (-6dB) 1kHz / 4kHz	155° / 52°
Options	Impedance, colors, labels

Installation, Operation and Maintenance Procedures

- Unscrew lid, lead cable through cable gland, connect to terminal (70V or 100V) and select required tapping onto the transformer by moving the red wire.
- Fasten lid with a torque of 1,5 Nm.
- Fasten bracket to wall or ceiling with 1 to 3 screws. Available with stainless steel bracket
- To change the position of the loudspeaker, please adjust the bracket (by loosening / tightening the screws) as required.
- For optimum performance, always use the correct voltage / power and operate within the frequency limits as stated.
- Do not open loudspeaker when energized.
- This loudspeaker is supplied with two years warranty against defective materials and workmanship.