



Analogue GRP Explosion Proof Telephone

DESCRIPTION

1. Robust SMC 2600 glassfibre reinforced polyester die-cast body
2. IECEx certified, Type Ex e ib mb I IC T6 Gb.
3. Waterproof degree IP66, High temperature approval -30°C to +70°C
4. Analogue telephone matching with most PABX, PBX and PAX system
5. Telephone line powered. No external power or battery required
6. LCD display include, SUS Metal keypad 24digit, Magnetic reed hook-switch
7. Busy tone detection for auto release the line if line busy, Auto answer auto release line.
8. Ring sound 95 dB dfd in 1 m and 10 ringing tone melodies selectable
9. Listening by loudspeaker: 70dB in 1m
10. Phone book memory: 50 address (name & number) programmable
11. Full Soft lock: only dial out from phone book 50 memory address number
12. Half soft lock: limit to dial out starting number, e.g. "00852" area code
13. Dry contact for external control automation (Option)

Manual setting

- Welcome text programmable e.g: welcome to koontech telephone
- Full soft lock or half soft lock
- Ring speaker up to 4 level selectable
- Hands free talking sound up to 4 level selectable
- Handset receiver sound up to 4 level selectable
- Up to 9 Ring tone melodies selectable
- Back light up to 4 level selectable
- The dialing number
- Calling time counting



SPECIFICATION

Unit dimension	227 x 293 x 135mm
Unit Weight	5.8kg
LCD Display:	2 line alphanumerical display ICON or number or letter Up to 4 level back light selectable
Keypad	stainless steel flash mount Waterproof IP66. Ice protection 21 keys with number and ACE letter for program
Handset:	dynamic receiver with inductive coupling for hearing aids Electret type microphone with noise cancelling Stainless steel armoured handset hold over 170kg
Waterproof protection	IP66
Impact protection:	IK09
Call Flash transfer:	max:120ms
Dialling procedure:	DTMF
External function (Option):	external louder speaker additional earpiece headset ringl sounder
operation temperature:	-25°C to 60°C
Storage temperature:	-30°C to +70°C

INSTALLATION

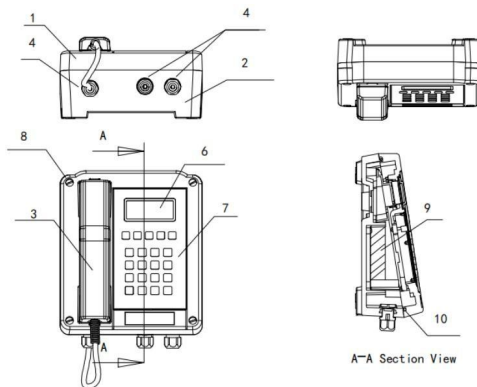

With mounting bar for installation

PACKING



Unit size:234*280*115mm N.W: 5.8KG

1pcs packing box size: 439 *277 *191mm N.W: 5.8KG G.W: 6.8KG

4pcs in 1 outer Carton box: size: 55*50*38cm N.W: 23.4KG G.W: 27.2KG

